

Junior Kangaroo Mathematical Challenge

Tuesday 13th June 2017

Organised by the United Kingdom Mathematics Trust

The Junior Kangaroo allows students in the UK to test themselves on questions set for young mathematicians from across Europe and beyond.

RULES AND GUIDELINES (to be read before starting):

1. Do not open the paper until the Invigilator tells you to do so.
2. Time allowed: **1 hour**.
No answers, or personal details, may be entered after the allowed hour is over.
3. The use of rough paper is allowed; **calculators** and measuring instruments are **forbidden**.
4. Candidates in England and Wales must be in School Year 8 or below.
Candidates in Scotland must be in S2 or below.
Candidates in Northern Ireland must be in School Year 9 or below.
5. **Use B or HB pencil only**. For each question mark *at most one* of the options A, B, C, D, E on the Answer Sheet. Do not mark more than one option.
6. Five marks will be awarded for each correct answer to Questions 1 - 15.
Six marks will be awarded for each correct answer to Questions 16 - 25.
7. *Do not expect to finish the whole paper in 1 hour*. Concentrate first on Questions 1-15. When you have checked your answers to these, have a go at some of the later questions.
8. The questions on this paper challenge you **to think**, not to guess. Though you will not lose marks for getting answers wrong, you will undoubtedly get more marks, and more satisfaction, by doing a few questions carefully than by guessing lots of answers.

*Enquiries about the Junior Kangaroo should be sent to: Maths Challenges Office,
School of Mathematics, University of Leeds, Leeds, LS2 9JT.*

(Tel. 0113 343 2339)

<http://www.ukmt.org.uk>

1. Kieran the Kangaroo takes 6 seconds to make 4 jumps. How long does it take him to make 30 jumps?

A 30 seconds B 36 seconds C 42 seconds D 45 seconds E 48 seconds

2. Sophie wants to complete the grid shown so that each row and each column of the grid contains the digits 1, 2 and 3 exactly once. What is the sum of the digits she will write in the shaded cells?

1		
2	1	

A 2 B 3 C 4 D 5 E 6

3. Ben has exactly the right number of cubes, each of side 5 cm, to make a solid cube of side 1 m. He places the smaller cubes side by side to form a single row. How long is this row?

A 5 km B 400 m C 300 m D 20 m E 1 m

4. Beattie wants to walk from P to Q along the paths shown, always moving in the direction from P to Q .

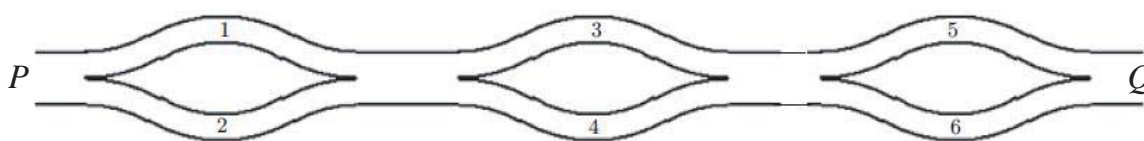

She will add the numbers on the paths she walks along. How many different totals could she obtain?

A 3 B 4 C 5 D 6 E 8

5. Anna is 13 years old. Her mother Annie is three times as old as Anna. How old will Annie be when Anna is three times as old as she is now?

A 13 B 26 C 39 D 52 E 65

6. Hasan writes down a two-digit number. He then writes the same two-digit number next to his original number to form a four-digit number. What is the ratio of his four-digit number to his two-digit number?

A 2 : 1 B 100 : 1 C 101 : 1 D 1001 : 1 E It depends on his number

7. A square piece of card has perimeter 20 cm. Charlie cuts the card into two rectangles. The perimeter of one of the rectangles is 16 cm. What is the perimeter of the other rectangle?

A 4 cm B 8 cm C 10 cm D 12 cm E 14 cm

8. Niko counted a total of 60 birds perching in three trees. Five minutes later, 6 birds had flown away from the first tree, 8 birds had flown away from the second tree and 4 birds had flown away from the third tree. He noticed that there was now the same number of birds in each tree. How many birds were originally perched in the second tree?

A 14 B 18 C 20 D 21 E 22

9. Alex colours all the small squares that lie on the two longest diagonals of a square grid. She colours 2017 small squares. What is the size of the square grid?

A 1009×1009 B 1008×1008 C 2017×2017 D 2016×2016 E 2015×2015

10. In the sequence of letters KANGAROOKANGAROOKANG... the word KANGAROO is repeated indefinitely. What is the 2017th letter in this sequence?

A K B N C G D R E O

11. A cube has diagonals drawn on three adjacent faces as shown in the diagram. Which of the following nets could Usman use to make the cube shown?

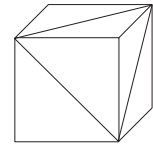

- A B C D E none of those shown

12. Maddie has a paper ribbon of length 36 cm. She divides it into four rectangles of different lengths. She draws two lines joining the centres of two adjacent rectangles as shown.



What is the sum of the lengths of the lines that she draws?

- A 18 cm B 17 cm C 20 cm D 19 cm E It depends upon the sizes of the rectangles
13. In trapezium $PQRS$, $\angle RSP = 2 \times \angle SPQ$ and $\angle SPQ = 2 \times \angle PQR$. Also $\angle QRS = k \times \angle PQR$. What is the value of k ?

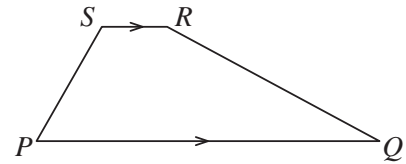

- A 2 B 3 C 4 D 5 E 6

14. Taran thought of a whole number and then multiplied it by either 5 or 6. Krishna added 5 or 6 to Taran's answer. Finally Eshan subtracted either 5 or 6 from Krishna's answer. The final result was 73. What number did Taran choose?

- A 10 B 11 C 12 D 13 E 14

15. In the diagram, $PRSV$ is a rectangle with $PR = 20$ cm and $PV = 12$ cm. Jeffrey marks points U and T on VS and Q on PR as shown. What is the shaded area?

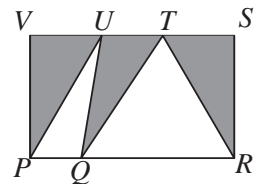

- A More information needed B 60 cm^2
C 100 cm^2 D 110 cm^2 E 120 cm^2

16. The line PQ is divided into six parts by the points V, W, X, Y and Z . Squares are drawn on PV, VW, WX, XY, YZ and ZQ as shown in the diagram. The length of line PQ is 24 cm. What is the length of the path from P to Q indicated by the arrows?

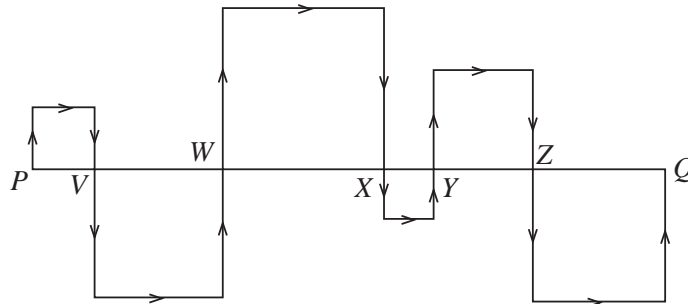

- A 48 cm B 60 cm C 66 cm D 72 cm E 96 cm

17. Henna has four hair ribbons of width 10 cm. When she measures them, she finds that each ribbon is 25 cm longer than the next smallest ribbon. She then arranges the ribbons to form two different shapes as shown in the diagram. How much longer is the perimeter of the second shape than the perimeter of the first shape?

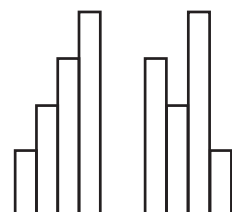

- A 75 cm B 50 cm C 25 cm D 20 cm E 0 cm

18. In the diagram, $PQRS$ is a square of side 10 cm. T is a point inside the square so that $\angle SPT = 75^\circ$ and $\angle TSP = 30^\circ$. What is the length of TR ?

A 8 cm B 8.5 cm C 9 cm D 9.5 cm E 10 cm

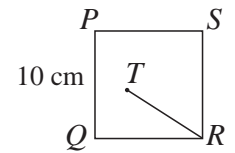

19. In the diagram, $PQRS$ and $WXYZ$ are congruent squares. The sides PS and WZ are parallel. The shaded area is equal to 1 cm^2 .

What is the area of square $PQRS$?

A 1 cm^2 B 2 cm^2 C $\frac{1}{2} \text{ cm}^2$ D $1\frac{1}{2} \text{ cm}^2$ E $\frac{3}{4} \text{ cm}^2$

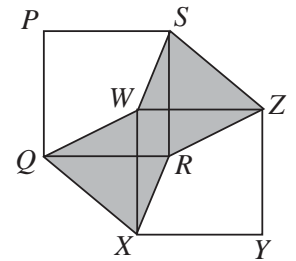

20. The multiplication $abc \times de = 7632$ uses each of the digits 1 to 9 exactly once. What is the value of b ?

A 1 B 4 C 5 D 8 E 9

21. Rory uses four identical standard dice to build the solid shown in the diagram.

Whenever two dice touch, the numbers on the touching faces are the same. The numbers on some of the faces of the solid are shown. What number is written on the face marked with question mark?

(On a standard die, the numbers on opposite faces add to 7.)

A 6 B 5 C 4 D 3 E 2

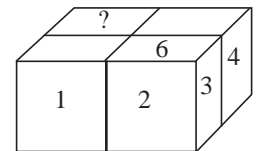

22. Harriet tells Topaz that she is thinking of three positive integers, not necessarily all different. She tells her that the product of her three integers is 36. She also tells her the sum of her three integers. However, Topaz still cannot work out what the three integers are.

What is the sum of Harriet's three integers?

A 10 B 11 C 13 D 14 E 16

23. Three congruent isosceles trapeziums are assembled to form an equilateral triangle with a hole in the middle, as shown in the diagram.

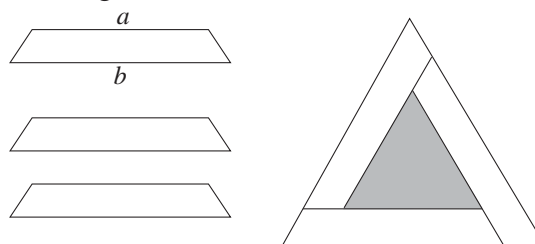

What is the perimeter of the hole?

A $3a + 6b$ B $3b - 6a$ C $6b - 3a$ D $6a + 3b$ E $6a - 3b$

24. Jacob and Zain take pencils from a box of 21 pencils without replacing them. On Monday Jacob takes $\frac{2}{3}$ of the number of pencils that Zain takes. On Tuesday Jacob takes $\frac{1}{2}$ of the number of pencils that Zain takes. On Wednesday morning the box is empty. How many pencils does Jacob take?

A 8 B 7 C 6 D 5 E 4

25. How many three-digit numbers are equal to 34 times the sum of their digits?

A 0 B 1 C 2 D 3 E 4

Tuesday 13th June 2017 Junior Kangaroo Solutions

1. **D** Kieran makes 4 jumps in 6 seconds so makes 2 jumps in 3 seconds. Therefore it will take him $(30 \div 2) \times 3$ seconds = 45 seconds to make 30 jumps.

2. **C** Label the numbers to be written in the cells of the grid as shown.

1	a	b
2	1	c
d	e	f

Each row and column contains the digits 1, 2 and 3 exactly once. Hence $c = d = 3$. Therefore $b = e = 2$ (and $a = 3$ and $f = 1$ for completeness). Hence the sum of the digits in the shaded cells is $2 + 2 = 4$.

3. **B** The number of small cubes along each edge of the large cube is $100 \div 5 = 20$. Therefore Ben has $20 \times 20 \times 20 = 8000$ small cubes in total. Hence the row he forms is 8000×5 cm = 40 000 cm long. Since there are 100 cm in 1 m, his row is 400 m long.
4. **B** The smallest and largest totals Beattie can obtain are $1 + 3 + 5 = 9$ and $2 + 4 + 6 = 12$ respectively. Totals of 10 and 11 can also be obtained, for example from $2 + 3 + 5 = 10$ and $1 + 4 + 6 = 11$. Therefore, since all Beattie's totals will be integers, she can obtain four different totals.
5. **E** When Anna is 13, Annie is $3 \times 13 = 39$ and so Annie is 26 years older than Anna. When Anna is three times as old as she is now, she will be 39 and Annie will still be 26 years older. Therefore Annie will be 65.
6. **C** Let Hasan's two-digit number be ' ab ', which is equal to $10a + b$. The four-digit number he forms is therefore ' $abab$ ', which is equal to $1000a + 100b + 10a + b$ and hence to $100(10a + b) + 10a + b = 101 \times (10a + b)$. Therefore the ratio of his four-digit number to his two-digit number is 101 : 1.

7. **E** The length of the edge of Charlie's original square is $(20 \div 4)$ cm = 5 cm. Since he cuts his square into two rectangles, he cuts parallel to one side of the square to create two rectangles each with two sides 5 cm long as shown in the diagram.

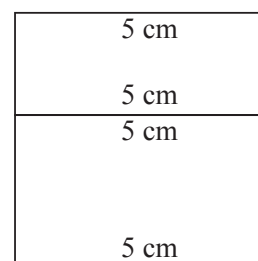

Hence the total perimeter of his two rectangles is 2×5 cm = 10 cm longer than the perimeter of his square. Since the perimeter of one of the rectangles is 16 cm, the perimeter of the other rectangle is $(20 + 10 - 16)$ cm = 14 cm.

8. **E** Let the number of birds remaining in each tree be x . Therefore $x + 6 + x + 8 + x + 4 = 60$, which has solution $x = 14$. Hence the number of birds originally perched in the second tree is $14 + 8 = 22$.
9. **A** The two longest diagonals of an $n \times n$ square grid each contain n squares. When n is an odd number, the two diagonals meet at the square in the centre of the grid and hence there are $2n - 1$ squares in total on the diagonals. Alex coloured 2017 squares and hence $2n - 1 = 2017$, which has solution $n = 1009$. Therefore the size of the square grid is 1009×1009 .

10. **A** The sequence KANGAROOKANGAROOKANG... repeats every 8 letters. Since $2017 = 8 \times 252 + 1$, the 2017th letter in the sequence is the first of the repeating sequence and hence is K.

11. **D** On each net, label the four vertices of the right-hand square 1, 2, 3 and 4 as shown. Also label any vertex on any of the other squares that will meet vertices 1, 2, 3 or 4 when the net of the cube is assembled into a cube with the corresponding value.

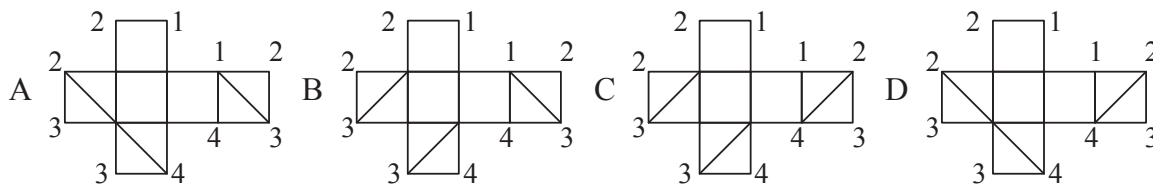

Since there are three vertices of the original cube at which two diagonals meet, to be a suitable net for the cube shown, any diagonal drawn meets another diagonal at a vertex with the same label. As can be seen, only in net D are the ends of the diagonals at vertices with the same label. Therefore Usman could only use net D to make the cube shown.

12. **A** Let the lengths of the four rectangles be p cm, q cm, r cm and s cm with $p + q + r + s = 36$. The lines Maddie draws join the centres of two pairs of rectangles and hence have total length $(\frac{1}{2}p + \frac{1}{2}q)$ cm + $(\frac{1}{2}r + \frac{1}{2}s)$ cm = $\frac{1}{2}(p + q + r + s)$ cm. Therefore the sum of the lengths of the lines she draws is $\frac{1}{2} \times 36$ cm = 18 cm.

13. **D** Let the size in degrees of $\angle PQR$ and of $\angle QRS$ be x and kx . Therefore the size of $\angle SPQ$ and of $\angle RSP$ are $2x$ and $2 \times 2x = 4x$ respectively. Since the angles between parallel lines (sometimes called co-interior or allied angles) add to 180° , we have $2x + 4x = 180$. This has solution $x = 30$. Similarly $x + kx = 180$ and hence $30k = 150$. Therefore the value of k is 5.

14. **C** Let Taran's original number be x . When he multiplied it, he obtained either $5x$ or $6x$. When Krishna added 5 or 6, his answer was one of $5x + 5$, $5x + 6$, $6x + 5$ or $6x + 6$. Finally, when Eshan subtracted 5 or 6, his answer was one of $5x$, $5x + 1$, $6x$, $6x + 1$, $5x - 1$, $5x$, $6x - 1$ or $6x$. Since the final result was 73 and since 73 is neither a multiple of 5 or 6, nor 1 less than a multiple of 5 or 6, nor 1 more than a multiple of 5, the only suitable expression for the answer is $6x + 1$. The equation $6x + 1 = 73$ has solution $x = 12$. Hence the number Taran chose is 12.

15. **E** Consider the two unshaded triangles. Each has height equal to 12 cm and hence their total area is $(\frac{1}{2} \times PQ \times 12 + \frac{1}{2} \times QR \times 12)$ cm² = $6 \times (PQ + QR)$ cm² = 6×20 cm² = 120 cm². Therefore the shaded area is $(20 \times 12 - 120)$ cm² = 120 cm².

16. **D** The path indicated follows three sides of each of the squares shown. The sum of the lengths of one side of each square is equal to the length of PQ , which is 24 cm. Therefore the length of the path is 3×24 cm = 72 cm.

17. **B** Let the length of the shortest ribbon be x cm. Therefore the lengths of the other ribbons are $(x + 25)$ cm, $(x + 50)$ cm and $(x + 75)$ cm. The perimeter of the first shape (starting from the lower left corner and working clockwise) is $(x + 10 + 25 + 10 + 25 + 10 + 25 + 10 + x + 75 + 40)$ cm = $(2x + 230)$ cm while the perimeter of the second shape (again starting from the lower left corner) is $(x + 50 + 10 + 25 + 10 + 50 + 10 + 75 + 10 + x + 40)$ cm = $(2x + 280)$ cm. Hence the difference between the two perimeters is $(2x + 280)$ cm - $(2x + 230)$ cm = 50 cm.

18. E Draw in lines PT and TS as shown. Since angles in a triangle add to 180° and we are given $\angle SPT = 75^\circ$ and $\angle TSP = 30^\circ$, we obtain $\angle PTS = 75^\circ$. Therefore $\triangle PTS$ is isosceles and hence $TS = PS = 10$ cm. Therefore, since $RS = 10$ cm as it is a side of the square, $\triangle RST$ is also isosceles. Since $\angle RSP = 90^\circ$ and $\angle TSP = 30^\circ$, we have $\angle RST = 60^\circ$. Therefore $\triangle RST$ is isosceles with one angle equal to 60° . Hence $\triangle RST$ is equilateral and therefore the length of TR is 10 cm.

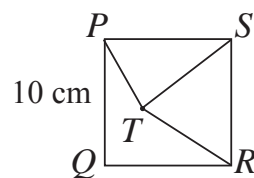

19. A Let the length of a side of $PQRS$ and of $WXYZ$ be x cm. Consider quadrilateral $QXRW$.

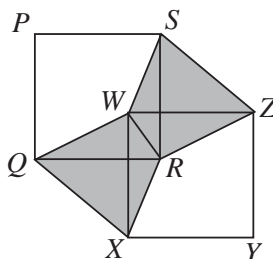

The diagonals QR and WX are perpendicular and of length x cm. Therefore the area of $QXRW$ is half the area of a rectangle with sides equal in length to QR and WX and hence is equal to $\frac{1}{2} \times QR \times WX = \frac{1}{2}x^2$ cm². Similarly, the area of quadrilateral $SWRZ$ is also $\frac{1}{2}x^2$ cm². Therefore the total shaded area is x^2 cm². However, the question tells us that the shaded area is equal to 1 cm². Therefore $x^2 = 1$. Hence the area of $PQRS$ is 1 cm².

20. C Note first that $7632 = 2 \times 2 \times 2 \times 2 \times 3 \times 3 \times 53$. Therefore either the two-digit number $de = 53$ or the three-digit number abc is a multiple of 53. Since the multiplication uses each of the digits 1 to 9 once and 7632 contains a 3, the option $de = 53$ is not allowable. Hence we need to find a three-digit multiple of 53 that does not share any digits with 7632 and divides into 7632 leaving an answer that also does not share any digits with 7632. We can reject $2 \times 53 = 106$ since it contains a 6 but $3 \times 53 = 159$ is a possibility. The value of $7632 \div 159$ is $2 \times 2 \times 2 \times 2 \times 3 = 48$ which does not have any digits in common with 7632 nor with 159. We can also check that no other multiple of 53 will work. Therefore the required multiplication is $159 \times 48 = 7632$ and hence the value of b is 5.

21. B The information in the question tells us that the numbers on touching faces of the solid are the same and that numbers on opposite faces of a die add to 7.

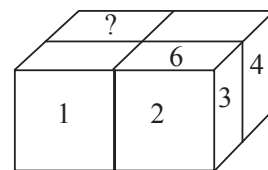

Since the number 4 is visible on the rear of the right-hand side of the solid, there is a 3 on the left-hand face of the rear right die and hence a 3 and a 4 on the right- and left-hand faces of the rear left die. Similarly, since the number 1 is visible on the left-hand side of the front of the solid, there is a 6 and a 1 on the front and back faces of the rear left die. Therefore the top and bottom faces of the rear left die have a 2 and a 5 written on them. Since the four dice are identical, comparison with the front right die of the solid tells us that a die with a 6 on its front face and a 3 on its right-hand face has a 2 on its lower face and hence a 5 on its upper face.

22. C The possible groups of three integers with product 36 are (1, 1, 36), (1, 2, 18), (1, 3, 12), (1, 4, 9), (1, 6, 6), (2, 2, 9), (2, 3, 6) and (3, 3, 4) with sums 38, 21, 16, 14, 13, 13, 11 and 10 respectively. The only value for the sum that occurs twice is 13. Hence, since Topaz does not know what the three integers chosen are, the sum of Harriet's three integers is 13.

23. **E** Since the triangle formed when the trapeziums are put together is equilateral, the smaller angles in the isosceles trapeziums are both 60° . Consider one trapezium split into a parallelogram and a triangle as shown.

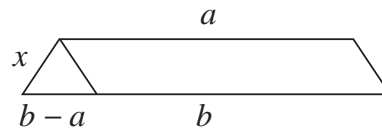

Since the original trapezium contains two base angles of 60° , the triangle also contains two base angles of 60° . Hence the triangle is equilateral and has side length $(b - a)$. Now consider the large equilateral triangle with the hole. The perimeter of the hole is $3(a - x)$ where x is the length of the shortest sides of the trapezium. Therefore the perimeter of the hole is $3(a - (b - a)) = 3(2a - b) = 6a - 3b$.

24. **A** Let the number of pencils Zain takes on Monday and Tuesday be x and y respectively. Therefore $x + \frac{2}{3}x + y + \frac{1}{2}y = 21$. Hence, when we multiply the equation through by 6 to eliminate the fractions and simplify, we obtain $10x + 9y = 126$. Since x and y are both positive integers and since the units digit of $10x$ is 0, the units digit of $9y$ is 6 and hence $y = 4$. Therefore $x = 9$ and hence the number of pencils Zain takes is $9 + 4 = 13$. Therefore the number of pencils Jacob takes is $21 - 13 = 8$.
25. **E** Let the three-digit number be $100a + 10b + c$. Since each suitable number is 34 times the sum of its digits, we have $100a + 10b + c = 34(a + b + c)$. Therefore $66a - 33c = 24b$. Since the left-hand side of this equation is a multiple of 11, the right-hand side is also a multiple of 11 and hence $b = 0$. Therefore $66a - 33c = 0$ and hence $c = 2a$. Therefore the three-digit numbers with the required property are 102, 204, 306 and 408 and hence there are four three-digit numbers with the required property.